

Revolutionizing  
Flight

**RFID Optimizes  
Maintenance  
Efficiency**

787 Flight Deck  
Offers Efficiency,  
Comfort, and  
Commonality

747-8 New  
Environmental  
Control System

Making Structural  
Repairs Faster  
and More Cost  
Effective

# AERO



# AERO

03

## Revolutionizing Flight

As airlines take delivery of the 787 and 747-8, Boeing technical experts are on hand to ensure a smooth transition.



03

05

## RFID Integrated Solutions System Optimizes Maintenance Efficiency

A series of integrated technologies and maintenance process improvements helps airlines improve their overall maintenance efficiency and performance.



05

11

## Innovative 787 Flight Deck Designed for Efficiency, Comfort, and Commonality

The 787 flight deck enhances safety while balancing innovation, cost, and operational commonality with previous Boeing flight decks.



11

19

## Inside the 747-8 New Environmental Control System

The 747-8 system increases cooling capacity, improves performance and maintainability, and provides a common 747 platform with simplified flight deck interfaces.



19

27

## Making Structural Repairs Faster and More Cost Effective

Boeing is taking dramatically less time to develop and publish updates to its structural repair manuals.



27

# AERO

**Publisher**

Shannon Myers

**Editorial director**

Jill Langer

**Editor-in-chief**

Jim Lombardo

**Design**

Methodologie

**Writer**

Jeff Fraga

**Distribution manager**

Nanci Moultrie

**Cover photography**

Jeff Corwin

**Printer**

ColorGraphics

**Web site design**

Methodologie

**Editorial Board**

Don Andersen, Gary Bartz, Richard Breuhaus, Tom Dodt, Justin Hale, Darrell Hokuf, Al John, Doug Lane, Jill Langer, Russell Lee, Duke McMillin, David Presuhn, Wade Price, Frank Santoni, Jerome Schmelzer

**Technical Review Committee**

Gary Bartz, Richard Breuhaus, David Carbaugh, Tom Dodt, Justin Hale, Darrell Hokuf, Al John, Doug Lane, Jill Langer, Russell Lee, Duke McMillin, David Palmer, David Presuhn, Wade Price, Jerome Schmelzer, William Tsai

**AERO Online**

[www.boeing.com/commercial/aeromagazine](http://www.boeing.com/commercial/aeromagazine)

*AERO* magazine is published quarterly by Boeing Commercial Airplanes and is distributed at no cost to operators of Boeing commercial airplanes. *AERO* provides operators with supplemental technical information to promote continuous safety and efficiency in their daily fleet operations.

The Boeing Company supports operators during the life of each Boeing commercial airplane. Support includes stationing Field Service representatives in more than 60 countries, furnishing spare parts and engineering support, training flight crews and maintenance personnel, and providing operations and maintenance publications.

Boeing continually communicates with operators through such vehicles as technical meetings, service letters, and service bulletins. This assists operators in addressing regulatory requirements and Air Transport Association specifications.

Copyright © 2012 The Boeing Company

Information published in *AERO* magazine is intended to be accurate and authoritative. However, no material should be considered regulatory-approved unless specifically stated. Airline personnel are advised that their company's policy may differ from or conflict with information in this publication. Customer airlines may republish articles from *AERO* without permission if for distribution only within their own organizations. They thereby assume responsibility for the current accuracy of the republished material. All others must obtain written permission from Boeing before reprinting any *AERO* article.

Print copies of *AERO* are not available by subscription, but the publication may be viewed on the Web at [www.boeing.com/commercial/aeromagazine](http://www.boeing.com/commercial/aeromagazine).

Please send address changes to [me.boecom@boeing.com](mailto:me.boecom@boeing.com). Please send all other communications to *AERO* Magazine, Boeing Commercial Airplanes, P.O. Box 3707, MC 21-72, Seattle, Washington, 98124-2207, USA.  
E-mail: [WebMaster.BCA@boeing.com](mailto:WebMaster.BCA@boeing.com)

*AERO* is printed on Forest Stewardship Council™ Certified paper.





The 787 Dreamliner begins its six-month world tour in Beijing on December 5, 2011.

# Revolutionizing Flight

Last quarter marked a new era in aviation as Boeing delivered its first 787 and 747-8 airplanes to launch customers ANA and Cargolux. These great airplanes promise to give airlines and the traveling public a new and better experience in air travel.

Made from composite materials, the 787 Dreamliner is the first mid-sized airplane capable of flying long-range routes, which allows airlines to open new, nonstop routes. The 747-8 provides double-digit improvements in fuel economy and carbon emissions and generates a 30 percent smaller noise footprint than the 747-400.

Now — as airlines introduce these new airplanes into their fleets — Boeing technical experts are on hand to ensure that customers have everything they need for a smooth transition. We are ready to support these airplanes with the world-class customer service that you have come to expect from Boeing. It is part of our promise to provide products that revolutionize flight and take your operations to the next level.

You can read more about these exciting new airplanes in this issue of *AERO*. Featured are articles on the 787 flight deck on page 11 and the environmental control system new to the 747-8 on page 19.

We look forward to taking you and your customers into this new era of aviation. Thank you for operating Boeing airplanes.

**LOU MANCINI**

Senior Vice President,  
Boeing Commercial Aviation Services



Operators can reduce costs and inspection time, eliminate labor-intensive maintenance, and provide easy access to maintenance histories.

# RFID Integrated Solutions System Optimizes Maintenance Efficiency

Working exclusively with Fujitsu and a major U.S. airline, Boeing has developed, tested, and validated the airline industry's first comprehensive radio frequency identification device (RFID) and contact memory button (CMB) technology for commercial airplanes. This system can significantly reduce an airline's operating costs by eliminating untimely, labor-intensive maintenance while providing easy access to maintenance histories.

By **Phil Coop**, Program Manager, RFID Integrated Solutions

Boeing's RFID Integrated Solutions system employs unique tools such as RFID and CMB to automatically identify, track, and manage critical airplane parts. It is a comprehensive solution for a series of integrated technologies and maintenance process improvements that can help airlines improve their overall maintenance efficiency and performance.

By providing a comprehensive, turnkey solution, RFID Integrated Solutions eliminates the need and long lead time for operators to retrofit their fleets with automated identification technology themselves.

This article provides an overview of RFID Integrated Solutions and offers examples of how its use can save airlines time and reduce errors.

## A BETTER WAY TO MANAGE AIRPLANE COMPONENTS

RFID Integrated Solutions combines RFID tags and CMBs installed on parts and components throughout an airplane. RFID is an automated identification technology that uses radio frequency waves to transfer data between a reader and items that have RFID devices, or tags, affixed. The tags contain a microchip and antenna, and operate at internationally recognized

standard frequencies. The RFID tag is similar to a bar code but offers significant advantages. The RFID tag stores data and offers enhanced data collection, the ability to read without a direct view of the RFID label, a dynamic read/write capability, simultaneous reading and identification of multiple tags, and tolerance of harsh environments. CMBs are another form of automated identification technologies (AIT) used in this offering. There is significantly more information in a CMB, which is easily accessed by direct contact.

Information — such as part and serial numbers, manufacturing dates, and maintenance history — is stored on the tags and buttons. Technicians can use a handheld scanner to read and update

## Figure 1: Radio frequency identification device (RFID) scanner

By providing an easy-to-read view of emergency equipment within an airplane cabin, Boeing's RFID Integrated Solutions system eliminates the need for technicians to open and close compartments and use mirrors and flashlights, which adds time and can result in inaccurate data.

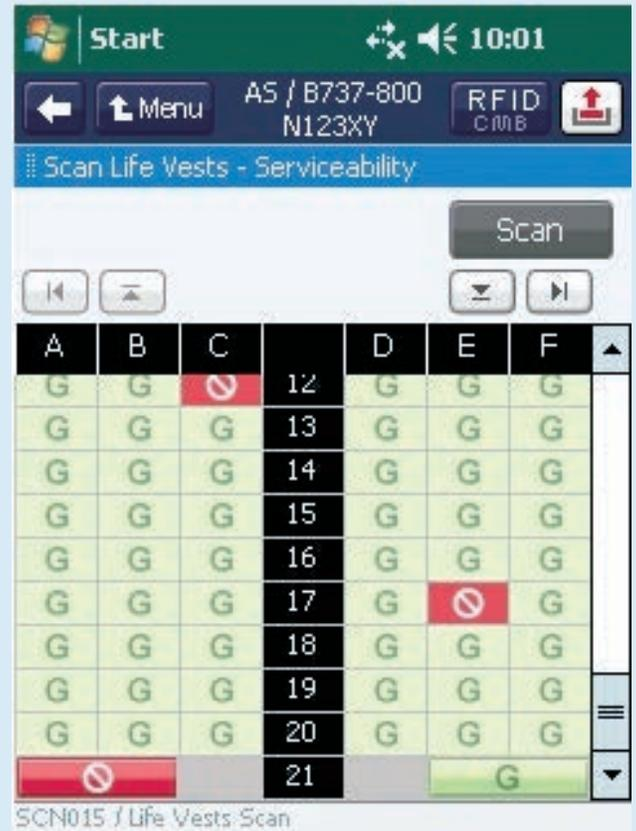

the RFID information wirelessly. This information then becomes an electronic record that travels with the airplane. RFID Integrated Solutions is the first fully integrated airborne automated identification technology program in commercial aviation.

RFID Integrated Solutions uses two distinct but related technologies to store and retrieve information about parts and components:

**Low-memory RFID.** These 512-bit to 1-kilobyte devices are used to store configuration, presence, security, and serviceability data. This data may include part and serial numbers, date of manufacture, expiration date, and location on the airplane.

**High-memory RFID and CMB.** These devices range in capacity from 8 kilobytes to 4 gigabytes and are used to store point-of-use lifecycle data about a part, component, or section of the airplane, including:

- **Birth record.** Pedigree and identity.
- **Current record.** Change in configuration, identity, or characteristics (such as hazardous materials or weight).

- **Maintenance history.** Actions taken and conditions noted; change in custody, accountability, and location; utilization and consumption; trends (such as no fault found).
- **Scratch pad.** Rewritable section that technicians can use to enter text or store photos or videos.

The initial deployment of RFID Integrated Solutions is focused on five areas. These areas were selected based on Boeing consultation with airlines on the operational needs of airlines during the development process of the RFID Integrated Solution system:

- Emergency equipment management (e.g., life vests, oxygen generators).
- Rotables management.
- Repairables management.
- Structural repair and airframe degradation management.
- Essential cabin items (e.g., carpet panels, floor panels, insulation blankets, seat covers, linens, and tapestries).

### EMERGENCY EQUIPMENT MANAGEMENT

The objectives of emergency equipment management include confirming that assets are present and where they should be, and that they are serviceable, not expired, or have not reached the threshold for time of expiration. RFID Integrated Solutions enables technicians to gather this information simply by walking through the airplane cabin with an RFID scanner. Seats, bins, compartments, and other areas where equipment is stored illuminate green on the scanner if the component is present and serviceable and red if it is missing, expired, or has been tampered with (see fig. 1).

RFID Integrated Solutions results in tremendous time savings. For example, it can reduce life-jacket inspection time by up to 85 percent and oxygen generator inspection time by up to 99 percent (see fig. 2). It can also reduce oxygen generator inventory by more than 50 percent and extend the generator lifecycle by up to 20 percent.

## Figure 2: 777 oxygen generator inspection

RFID Integrated Solutions reduces the time required for a 777 oxygen generator inspection from six and a half hours to 15 minutes, which represents a reduction of more than 90 percent.

### 777 O<sub>2</sub> General Inspection Before: 6.5-Hour Task

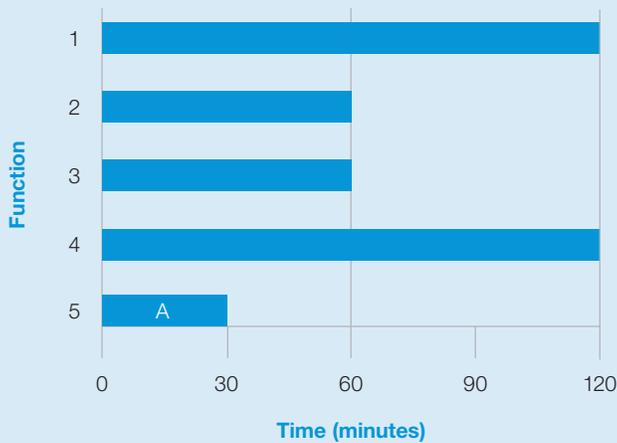

- |                   |                            |
|-------------------|----------------------------|
| 1 Open            | A Value-Added (VA) Task:   |
| 2 Search/Inspect  | Queue Time = 360 mins      |
| 3 Diagnose/Decide | Touch Time = 30 mins       |
| 4 Close           | Total Lead Time = 390 mins |
| 5 Document        | (VA = ~10%)                |

### 777 O<sub>2</sub> General Inspection After: 15-Minute Task

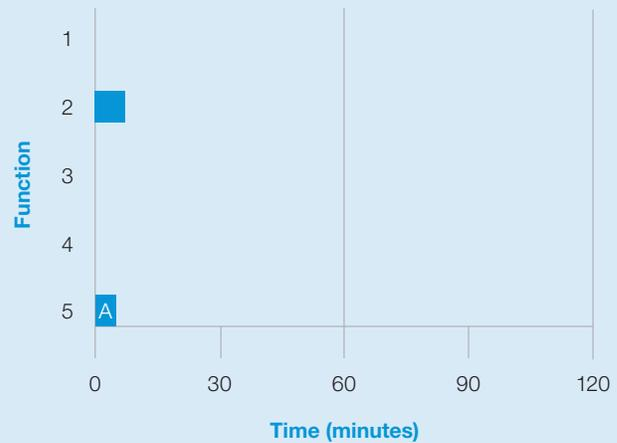

- |                   |                           |
|-------------------|---------------------------|
| 1 Open            | A Value-Added Task:       |
| 2 Search/Inspect  | Queue Time = 10 mins      |
| 3 Diagnose/Decide | Touch Time = 5 mins       |
| 4 Close           | Total Lead Time = 15 mins |
| 5 Document        | (VA = 33%)                |

## ROTABLES MANAGEMENT

The rotables management component of RFID Integrated Solutions enables operational efficiency across the entire rotatable component value stream by bringing critical decision-making data to the point of use and unprecedented visibility to the supply chain. RFID Integrated Solutions can help reduce inventory and maintenance lead time, improve troubleshooting, and increase product integrity while providing more comprehensive asset management.

RFID Integrated Solutions provides technicians with complete information about rotatable parts, including part number, birth record, and current record. A maintenance history section enables technicians to provide information such as when the part was installed, removed, or modified. Conditions such as leaks, noise, and extreme temperatures can also be noted directly on the part's RFID tag. Information stored on the tags can enhance parts traceability and reduce cycle time to solve in-service problems by improving the

accuracy of information exchanged between airlines and parts suppliers. All readers include the writing function as well.

The tag also provides technicians with up to 500 characters of free text that can be used to make more meaningful notes than are possible on the U.S. Federal Aviation Administration Form 8130-3 currently used. As parts travel through the supply chain, RFID Integrated Solutions makes it easy to see when they were shipped, received, and stored using a proprietary process to identify value-added information for each customer.

## REPAIRABLES MANAGEMENT

An RFID Integrated Solutions repairables management system can reduce queue time by up to 98 percent and dramatically improve parts utilization by giving operators increased visibility into their repairables supply chain.

In a typical scenario, a CMB is attached to a part and preloaded with information about that part. Simply by reading the CMB,

a technician can determine that the part is repairable and which shop is responsible for repairs. Alerts can be incorporated that, for example, inform the supply chain that a repairable part has been removed and is on its way to the repair shop.

While developing RFID Integrated Solutions, Boeing found that some repairable parts at one airline had a lead time averaging 431 days. The re-engineered process enables parts to move through the supply chain in just 12 days, a reduction of 97 percent. During the analysis, one airline discovered 87 instances of the same part in the queue — and had actually ordered three new replacement parts, not realizing it already had 87 repaired parts available.

## STRUCTURAL REPAIR AND AIRFRAME DEGRADATION MANAGEMENT

RFID Integrated Solutions can streamline heavy maintenance by enabling mechanics to use CMB tags to record all pertinent data about a structural repair, enabling the data to be located and reviewed easily

### Figure 3: Structural repairs and airframe degradation management system

With the traditional approach to structural repairs, mechanics can spend hours removing corrosion and waiting for inspection only to find that material removal has exceeded limits. RFID Integrated Solutions enables mechanics to read an affixed AIT device (installed in corrosion-prone areas and based on previously defined threshold) and make a decision to replace the part before wasting hours of time treating and inspecting.

#### Recurring Corrosion or Wear Scenario

Before:  
Decision in hours

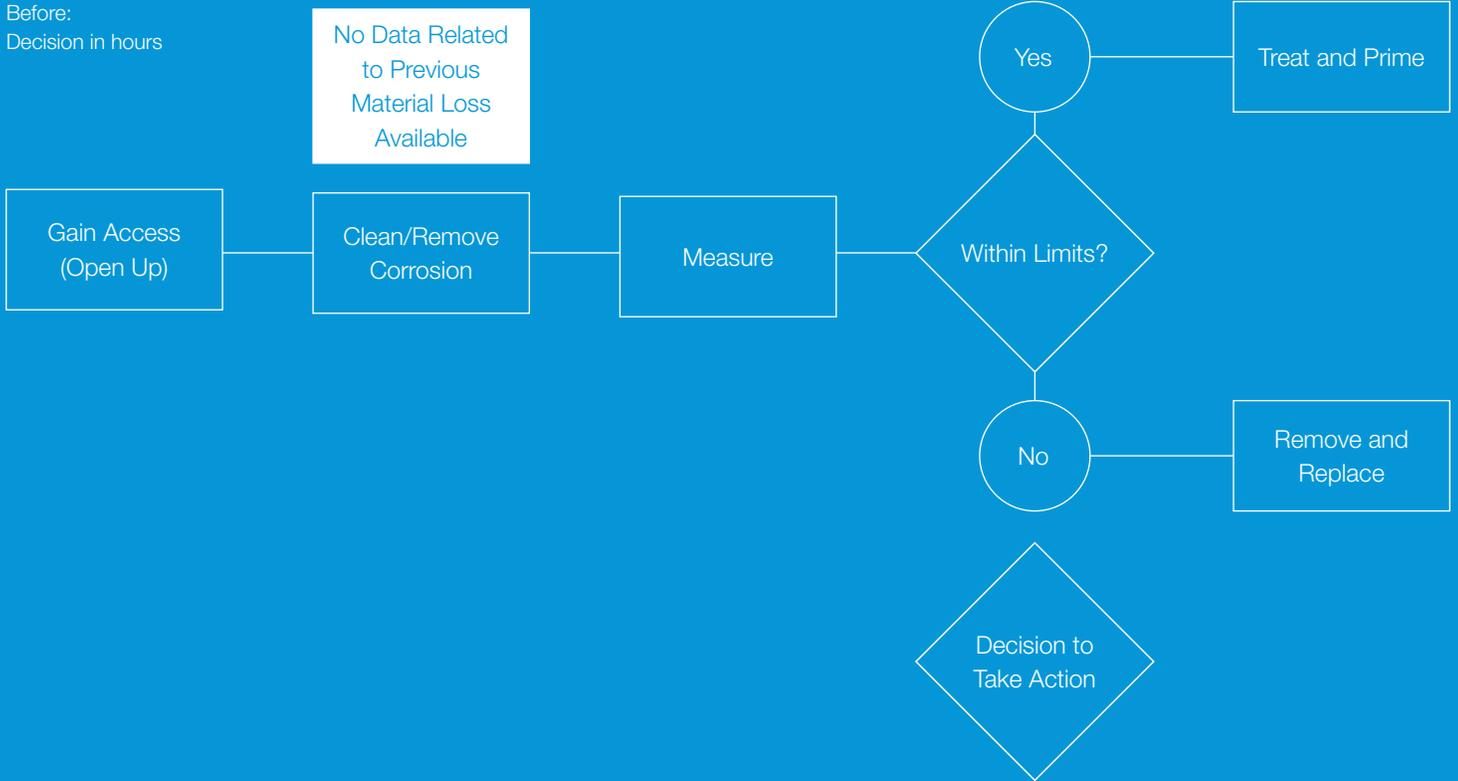

After:  
Decision in minutes

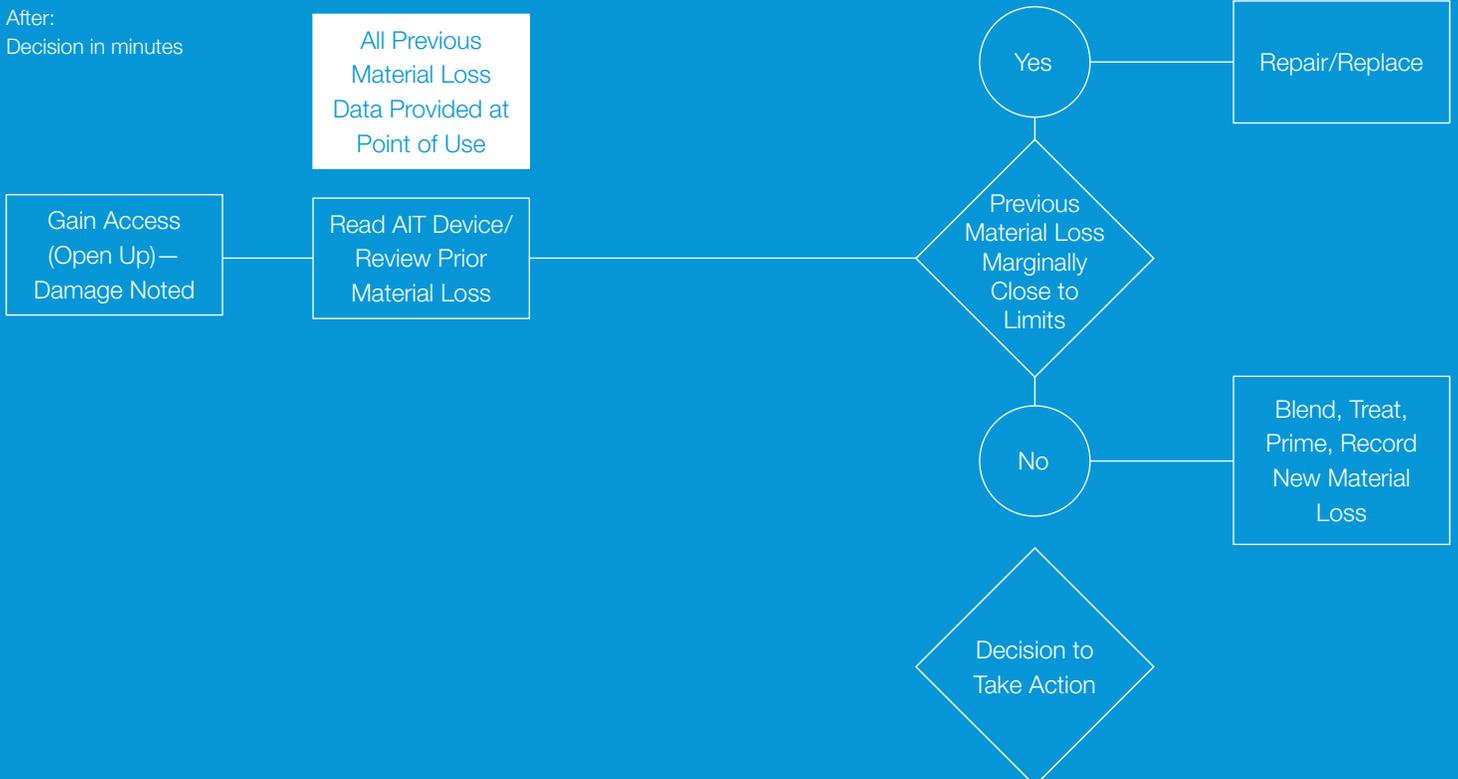

## Figure 4: Cabin interiors

RFID Integrated Solutions can mean a significant reduction in linens and tapestries — as much as 25 percent per ship set exchange. That can reduce inventory requirements as well.



during subsequent maintenance (see fig. 3). This is particularly valuable for composite structures and hidden repairs.

The application allows users to scan and store up to 4 gigabytes of data, including photos, PDF copies of repair orders, and recurring inspection requirements. By providing relevant data at the exact point of the repair, RFID Integrated Solutions can reduce the time required to make a repair decision by up to 99 percent. Other benefits include:

- **Structural repairs.** Capture damage information for the repair, including photos of damage and damage removal.
- **Component repairs.** Capture unique repairs and modifications, including photos and drawings.
- **Corrosion prevention and control program.** Capture previous corrosion removal and material loss directly at the point of high corrosion-prone areas.
- **Aging airplanes.** Capture records of repairs in critical zones.

RFID Integrated Solutions will provide richer and more frequent information about airplane components. The supporting documentation maintained by RFID Integrated Solutions will make it easier to sell or purchase an airplane.

### ESSENTIAL CABIN ITEMS

By providing a simple, fast way to determine the replacement history for large bulk cabin items (such as carpet panels, floor panels, insulation blankets, and seat covers), RFID Integrated Solutions enables maintenance personnel to remove only what is required (see fig. 4). This can extend the lifecycle of the items, reduce wash times, extend life of fire-resistant materials, and reduce lead time and hazardous waste removal.

This same approach can be used to track the maintenance history of freighter interior items, such as cargo loading system components, fire suppression systems, and interior trim.

### TAILORED APPROACH

Because each airline's requirements are unique, Boeing will tailor RFID solutions for each customer's needs; provide automated identification technology tag readers and software applications; integrate those solutions into the customer's operational environment; and establish a long-range plan that will expand automated identification technology solutions across the customer's enterprise.

A fleet retrofit to incorporate RFID Integrated Solutions can be integrated into

the airline's current maintenance schedule. Emergency equipment retrofits can be accomplished during an overnight check. Boeing provides retrofit kits, instructions, and technical oversight. No supplemental type certificate is required, and installation methods have received regulatory approval.

Boeing also provides a comprehensive training system that includes literature; syllabus; training aids and simulators; on-site, hands-on training; and a train-the-trainer program. Instructors are former airline engineering and maintenance staff with experience in both the RFID/CMB technology and airline operations.

### SUMMARY

Operators can reduce operating costs; reduce inspection time; eliminate untimely, labor-intensive maintenance; and provide easy access to maintenance histories with the airline industry's first comprehensive RFID and CMB technology for commercial airplanes. The system, developed by Boeing and Fujitsu, automatically identifies, tracks, and manages critical airplane parts, improving maintenance efficiency and performance.

For more information, please contact Phil Coop at [william.p.coop@boeing.com](mailto:william.p.coop@boeing.com). [A](#)



The 787 flight deck has been designed to balance innovation, cost, and operational commonality with previous Boeing airplane models.

# Innovative 787 Flight Deck Designed for Efficiency, Comfort, and Commonality

The flight deck of the new 787 Dreamliner introduces new technologies to help pilots work more efficiently and safely while maintaining significant operational commonality with previous generations of Boeing airplanes.

By **Randy Neville**, 787 Chief Pilot, and  
**Mike Dey**, Manager, Flight Deck Product Development

During the early development phase of the revolutionary 787 Dreamliner, the flight deck team was tasked with developing a design solution that would enhance safety while balancing innovation, cost, and operational commonality with previous Boeing flight decks. These key drivers were kept in the forefront as the team of engineers, pilots, and human factors experts took the initial flight deck concepts from paper layouts, to foam and cardboard ergonomic mockups, to functional prototype simulators, to final validation in full-scale hardware flight simulators.

Throughout the process, the design decisions and prototypes were shared with customer pilots and regulators for their input to help ensure that the key design

drivers were properly balanced. As a result of these efforts, the 787 flight deck incorporates a number of innovative features that offer opportunities for airlines to save money and enhance their competitiveness while maintaining operational commonality with the 777.

This article describes the 787 flight deck and how its design can help improve airline operations.

## ADVANCED FLIGHT DECK TECHNOLOGIES

The 787 advanced flight deck leverages state-of-the-art technology to improve operational capabilities and provide flight

crews with a clean, simplified look and feel (see fig. 4, on pages 14 and 15). The flight deck integrates new technologies while maintaining a significant amount of commonality with other Boeing airplanes, especially the 777. Familiar Boeing controls, displays, and procedures all support shorter transition periods to the 787 from other Boeing family members and enable economical mixed-fleet flying.

One of the 787 design goals was the ability to fly point to point to any runway end without the aid of ground navigation aids, and to do so with more flight crew situational awareness. By integrating dual global positioning system receivers with triple-redundant flight management systems, providing enhanced, simplified

flight crew approach capability using the integrated approach navigation concept introduced on the Next-Generation 737, and including this information on the dual head-up displays (HUDs), the 787 offers the capability to reliably perform required navigation performance (RNP) procedures far into the future, improving operational efficiency.

Other advanced features include communications and datalink capabilities that extend the integrated future air navigation system design introduced on the 777, ensuring access to any airspace and providing a platform for operating in future Next Generation Air Transportation System and Single European Sky Air Traffic Management environments while retaining a consistent Boeing flight deck operational philosophy. Two identical integrated surveillance systems provide reliable weather radar, transponder, traffic collision avoidance system, and ground proximity functionality. This redundancy improves dispatch safety and reliability and also provides a platform for growth to support future air traffic initiatives, such as Automatic Dependent Surveillance-Broadcast (ADS-B).

The total number of parts in the 787 flight deck has been reduced compared to other airplanes. The three tuning control panels located in the flight deck aisle stand were developed for the 787 and replace functionality that previously would have required several independent control panels. This consolidates crew interface functionality for communication and surveillance systems, reducing the number of unique aisle stand panels and increasing backup capability. An electronic version of the control display unit (CDU) interface for flight planning functions has eliminated large and costly hardware multifunction control and display units from the flight deck while maintaining the user interface look and feel familiar to pilots of previous models.

One of the more dramatic simplifications of the 787 flight deck is a result of the 787's "more-electric" architecture. Remote power distribution allows for the use of electronic circuit breakers, eliminating hundreds of physical circuit breakers from the flight deck. Flight crew awareness of system state is enhanced with visual information on every circuit interruption device, including those remotely located, via multifunction display (MFD) screens. The reduction in parts and improved design means lower operating costs and higher reliability. For example, the 787 requires just 13 line replaceable units (LRUs) to provide a full complement of flight deck display, communication, navigation, and surveillance capability. That's about half as many LRUs as other models require for the same capability.

The 787 flight deck's open avionics architecture design facilitates future upgrades, which can be made via software rather than more expensive hardware replacement or modification. "Soft-key" menus allow easier incorporation of technology upgrades by avoiding the need to install new physical buttons or switches into the LRUs. By design, future regulatory requirements and technology growth in areas such as communication, navigation, surveillance, and air traffic management will be easier to incorporate into the 787 flight deck.

The comfort of the pilots who will operate the 787 for decades to come was also a consideration of the design team. The pilot seats are designed to improve comfort, with additional adjustment capability. Acknowledging that the flight deck is the pilots' workspace for many hours on end, the amount of storage in the flight deck for pilot luggage and personal items such as large water bottles was increased. Pilots will also enjoy expansive views from the 787's large flight deck windows and appreciate the lowest noise levels of the fleet.

Other key flight deck features include:

**Large multifunction displays.** The 787 Dreamliner features the largest forward display screens of any certified airliner, with five MFDs that measure 15 inches diagonally (see fig. 1). The displays provide more than twice the area as those used on the 777, giving pilots more information and significant flexibility to tailor the display layout to their needs for each phase of flight. Standard features include an airport taxi map integrated into the forward navigation display, which enhances ground taxi safety and is a platform for future capability such as the display of ADS-B ground traffic in the airport environment.

An enhanced vertical situational display provides a graphic rendering of approaching terrain profiles and a clear picture of the flight management system's calculated and most efficient vertical flight profile, which supports RNP and continuous descent "green" approaches (see fig. 2). (For an explanation of RNP, see *AERO* second-quarter 2008.) The two outboard displays are a fixed format that provides primary flight display information combined with an "auxiliary" display that consolidates frequently referenced information for the crew, such as flight number, each pilot's microphone-selected radio and its frequency, and transponder code. The lower portion of the auxiliary display is reserved for important datalink messages, such as controller-pilot datalink communications and digital automated terminal information.

The three central MFDs can be split into independent formats or can be configured to provide a single large map. In addition to the navigation map, MFD formats include synoptic displays showing the state of major airplane systems, smart electronic checklists that integrate with airplane systems, an electronic CDU interface to flight management, and an area reserved for future growth. By consolidating numerous features, the large displays help reduce production and spares costs.

## Figure 1: Multifunction displays

The 787's large multifunction displays give pilots more information and the ability to tailor the display layout to their needs for each phase of flight.



## Figure 2: Vertical situational display below navigation display

The enhanced vertical situational display provides a graphic rendering of approaching terrain profiles and a clear picture of the flight management system's calculated and most efficient vertical flight profiles, supporting required navigation performance and continuous descent "green" approaches.

## Figure 3: Electronic flight bag

The electronic flight bag (EFB) is the digital equivalent of the pilot's flight bag. Dual EFBs are standard on the 787.



**Figure 4: The 787 flight deck**

The 787 flight deck is designed for comfort, safety, efficiency, and commonality with the 777.





### Figure 5: Head-up display

The basic and dual head-up displays promote “eyes out of the flight deck” flying for both pilots.



**Dual electronic flight bags (EFBs).** The 787's dual Class III touchscreen EFBs pave the way for paperless flight operations (see fig. 3). Other airplane avionics, the flight management computer, communications, and flight deck printer all work with the EFBs. The EFBs enable significant reductions in the amount of flight deck paper by providing a standard software suite. This suite contains information such as maps, charts, manuals, onboard maintenance functions, a performance tool, and a document browser, which can all be updated wirelessly or with a maintenance laptop. It also allows takeoff-performance calculations to be made in real time and transmitted to the flight management computers.

**Dual head-up displays.** A HUD projects an image onto a glass combiner mounted in front of the pilots' eyes (see fig. 5). It displays flight information so pilots can look outside the flight deck, scanning for traffic or flying an approach, and simultaneously view primary flight instruments. The dual HUDs enhance safety in all phases of flight, in both good or poor visibility. HUDs also enable lower visibility takeoff minimums by integrating with the navigation radios and flight management system to provide low visibility takeoff runway centerline guidance. The dual HUDs allow the first officer to be proficient in HUD use when transitioning to captain.

### OPERATIONAL COMMONALITY

Operational commonality is the similarity between airplanes in operating procedures, checklists, and flight crew interfaces. Commonality simplifies training and can decrease airline operating costs. To achieve operational commonality with the 777, the 787 team worked to ensure the new airplane would in many ways “feel” like a 777, while implementing new capabilities and simplifying the flight deck.

In the flight deck, commonality is created partly through the locations of displays, switches, and controls. One of the most notable decisions was to retain the traditional wheel-and-column pilot controls. Although the team studied other control mechanisms, including a side stick, a thorough analysis determined that the wheel-and-column arrangement provides the feedback and situational awareness pilots need to make and execute decisions during critical periods. On the 787, the wheel-and-column controllers:

- Are cross-linked between pilots to reduce potential confusion.
- Have large ranges of motion for improved peripheral cueing.
- Are back-driven to give pilots better visual and tactile understanding of what either the autoflight system or the other pilot is doing.

Advanced systems also help ensure that the feel of the airplanes is the same. The 787 digitally re-creates the feel and

functionality of the 777, but takes advantage of innovations in fly-by-wire flight controls to reduce weight and improve performance. New functionality such as gust suppression helps create a smoother ride without changing the way the pilot operates the airplane. This approach allows the airplane to offer improvements in comfort and efficiency with minimal impact on flight deck procedures, reducing crew training costs in transitioning from other models of the Boeing fleet.

The advantage of commonality is particularly evident in the reduced Boeing training courses needed for pilots to be qualified as 787 pilots. For an existing 777 pilot, it takes as few as five days of training to transition to the 787. Pilots of 757s and 767s will need only eight days of training. Today's 737 pilots will need 11 days of training for the 787. Pilots of other Boeing airplanes — 717, 727, and 747 — will need 13 days of training. Pilots with no experience in a Boeing flight deck will need 21 days of training.

### SUMMARY

The flight deck on the new 787 has been designed to balance innovation, cost, and operational commonality with previous Boeing airplane models.

For more information, please contact Randy Neville at [randall.l.neville@boeing.com](mailto:randall.l.neville@boeing.com). 



The new ECS on the 747-8 takes advantage of new technology to offer greater capacity, increased efficiency, and improved maintainability.

# Inside the 747-8 New Environmental Control System

The Boeing 747-8 includes a new environmental control system (ECS) that integrates the air supply control system and the cabin air-conditioning and temperature control system.

By **André Brasseur**, Service Engineer;  
**Will Leppert**, Service Engineer; and  
**Alexis Pradille**, Service Engineer, Liebherr Technical Services

The 747-8 ECS increases cooling capacity and improves performance and maintainability, while providing a common 747 platform with simplified flight deck interfaces.

The system's architecture integrates more functions in fewer line replaceable units (LRUs) to maximize efficiency and reliability and to simplify troubleshooting.

This article provides an overview of the design of the 747-8 ECS and in-service support.

## PERFORMANCE AND RELIABILITY

A robust ECS is important for cabin safety and comfort. The 747-8 uses an ECS that offers digital control, lighter weight,

increased reliability, and reduced maintenance compared to earlier technology. Changes to the air supply control system (ASCS) and cabin air-conditioning and temperature control system (CACTCS) combine to provide the 747-8 greater cooling capacity as well.

The 747-8 ECS uses new technologies to improve performance. These include an integrated air system controller (IASC) and the associated software. In addition, the system uses high-pressure water separation to dry out the air within the air cycle machine upstream of turbine section input, as well as pressure sensors to provide input to the IASC for icing control.

Combined, these technologies help improve the efficiency and reliability of the

system, allowing for increased efficiency of bleed air and a reduction in bleed air penalties. That, in conjunction with the improved maintainability achieved through the placement of LRUs and LRU components, helps reduce operating and maintenance costs.

Other key improvements in the new ECS include an advanced new bleed system and true subfreezing packs.

## ADVANCED BLEED SYSTEM

The 747-8 airplane is powered by General Electric GENX-2B engines. The engine bleed systems supply air from the engine compressor. There are four identical engine

The air-conditioning pack incorporates a water extraction loop within the pack to extract water and avoid ice formation at the ACM turbine outlet. This is accomplished by routing the air appropriately within the pack; water separation is accomplished within the pack itself as part of the air-conditioning process.

bleed systems per airplane with independent control and indication for each system (see fig. 1).

The air temperature and air pressure are regulated before being delivered to airplane systems. The bleed air is used for CACTCS, engine anti-ice, wing anti-ice, the hydraulic air-driven pump, the leading-edge flap drive unit, the nitrogen generation system, aft cargo heat, total air temperature probe aspiration, and hydraulic reservoir pressurization. All four engine bleed systems are connected by a common manifold.

Technological advancements enabled Boeing to make several improvements to the bleed system on the 747-8. These improvements include:

- **New digital bleed.** The system has no mechanical position switches and reduced use and consolidation of sensors.
- **No remote valve controllers.** The torque motor and solenoid are built into the valve design, allowing for easier troubleshooting and improved fault isolation.
- **Fewer servo/sense lines.** This increases system reliability.

#### 747-8 SUBFREEZING PACK

The 747-8 air-conditioning pack has several key features that allow it to be classified as a true subfreezing pack, which will operate to temperatures below the freezing point of water at all altitudes (see fig. 2). While earlier air-conditioning packs can drive subfreezing during all conditions, there are limitations that need to be placed upon the system due to the operating environment and the technology implemented within the system. As a result, below 25,000 feet (7,620 meters), where environmental icing is a factor, the pack turbine discharge (i.e., pack outlet) is limited to approximately 35 degrees F (1.67 degrees C) prior to mixing of recirculated air in the main distribution plenum. At cruise, where icing concerns are not a critical issue for operation, many packs do drive subfreezing as conditions warrant.

The 747-8 pack incorporates technology that enables it to function as a subfreezing conditioned air supply during all phases of operation, both on the ground and in flight. Key factors that enable this technology to

overcome environmental limitations include the use of:

- High-pressure water separation, which mitigates the buildup of ice within the air cycle machine (ACM).
- Integrated pack control features that mitigate ice formation within the air-conditioning pack.
- A compact mixing section at the turbine outlet of the pack, which allows recirculated air from the airplane ambient environment to be mixed directly with pack outlet air prior to implementing outlet discharge temperature limitations.

**High-pressure water separation.** The air-conditioning pack incorporates a water extraction loop within the pack to extract water and avoid ice formation at the ACM turbine outlet. This is accomplished by routing the air appropriately within the pack; water separation is accomplished within the pack itself as part of the air-conditioning process.

Air that has been heated in the ACM compressor section is first cooled by the main heat exchanger. The air is then further

## Figure 1: 747-8 engine bleed system

The system schematic (top) and component locations (bottom) in the 747-8 engine bleed system.

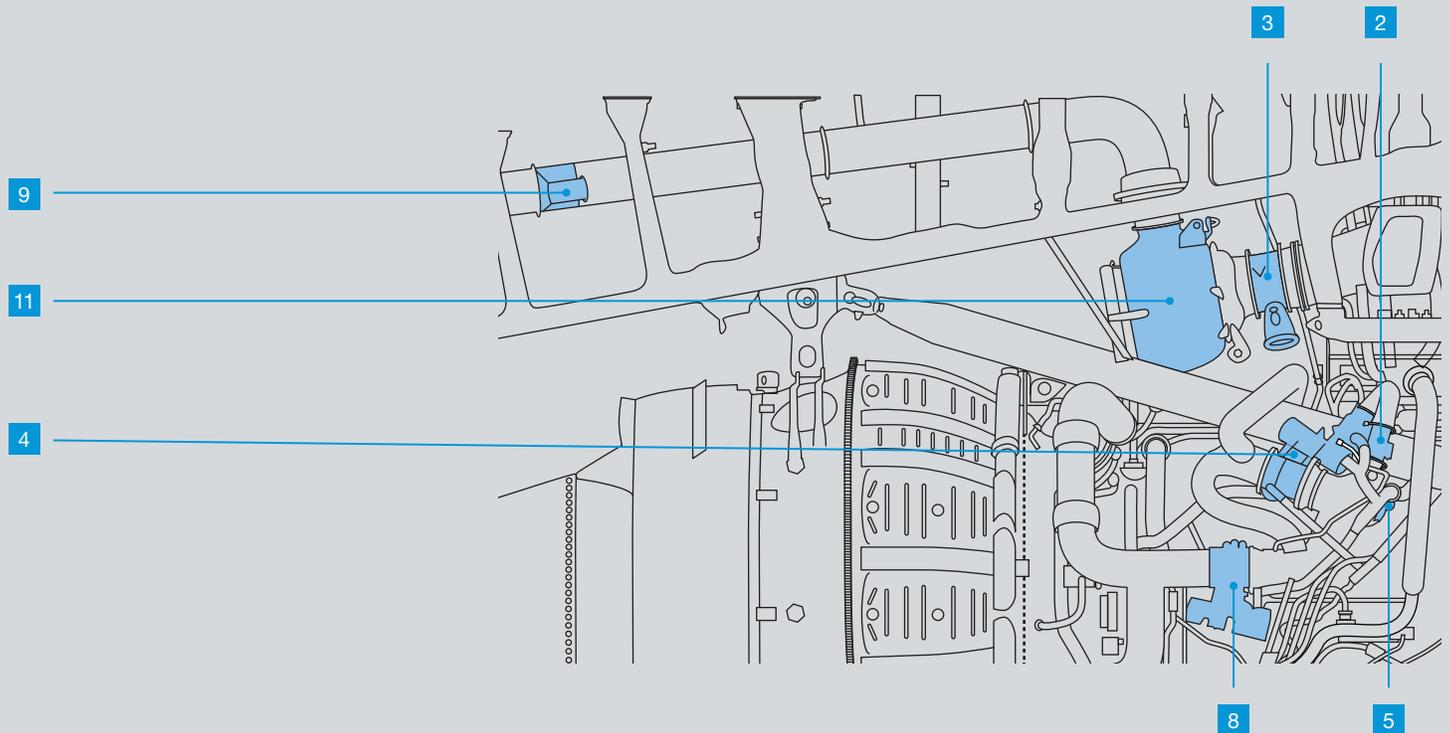
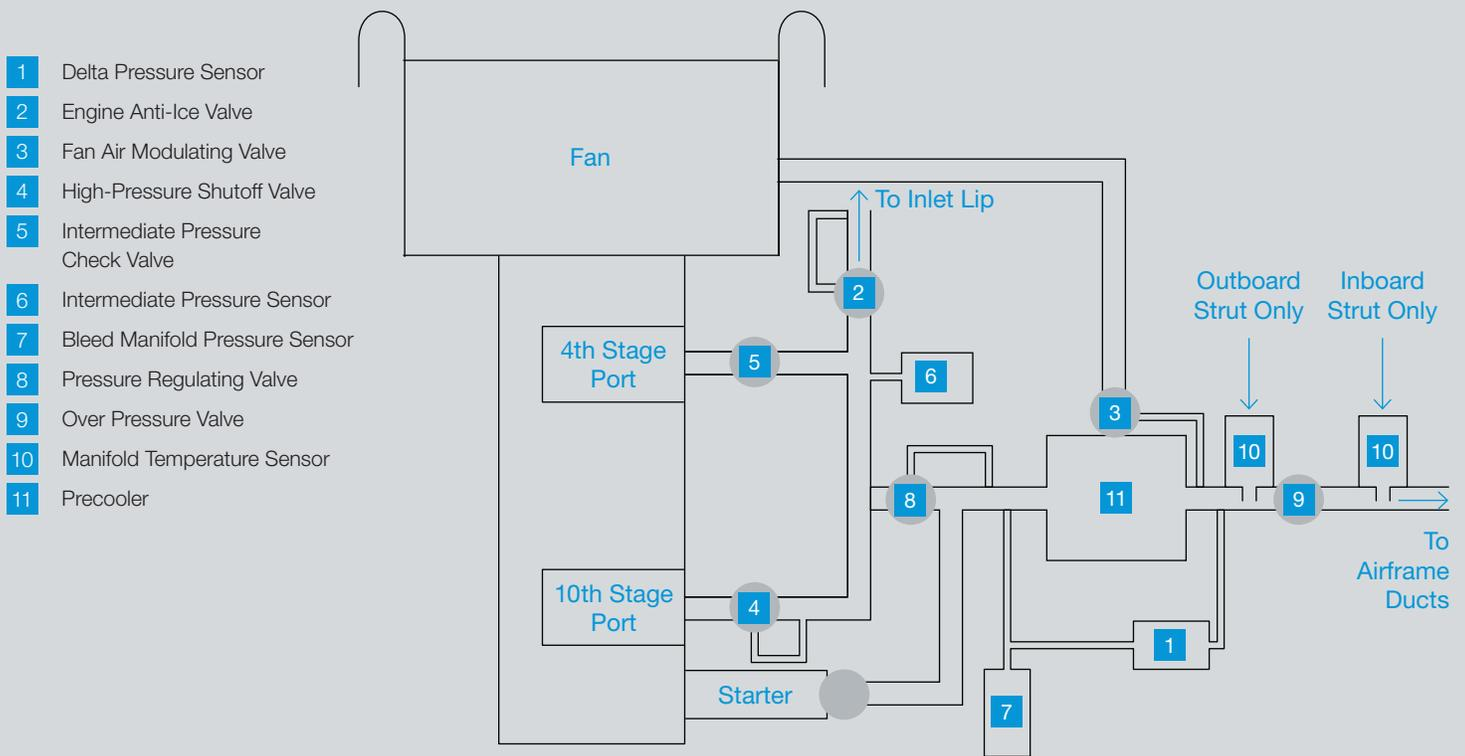

**Figure 2A: 747-400 air-conditioning pack system**

Compare this 747-400 to the 747-8 air-conditioning pack system shown in figure 2B. Note the locations of the respective water separator/extractor systems as well as the pack temperature sensor relative to the mixer discharge temperature sensor.

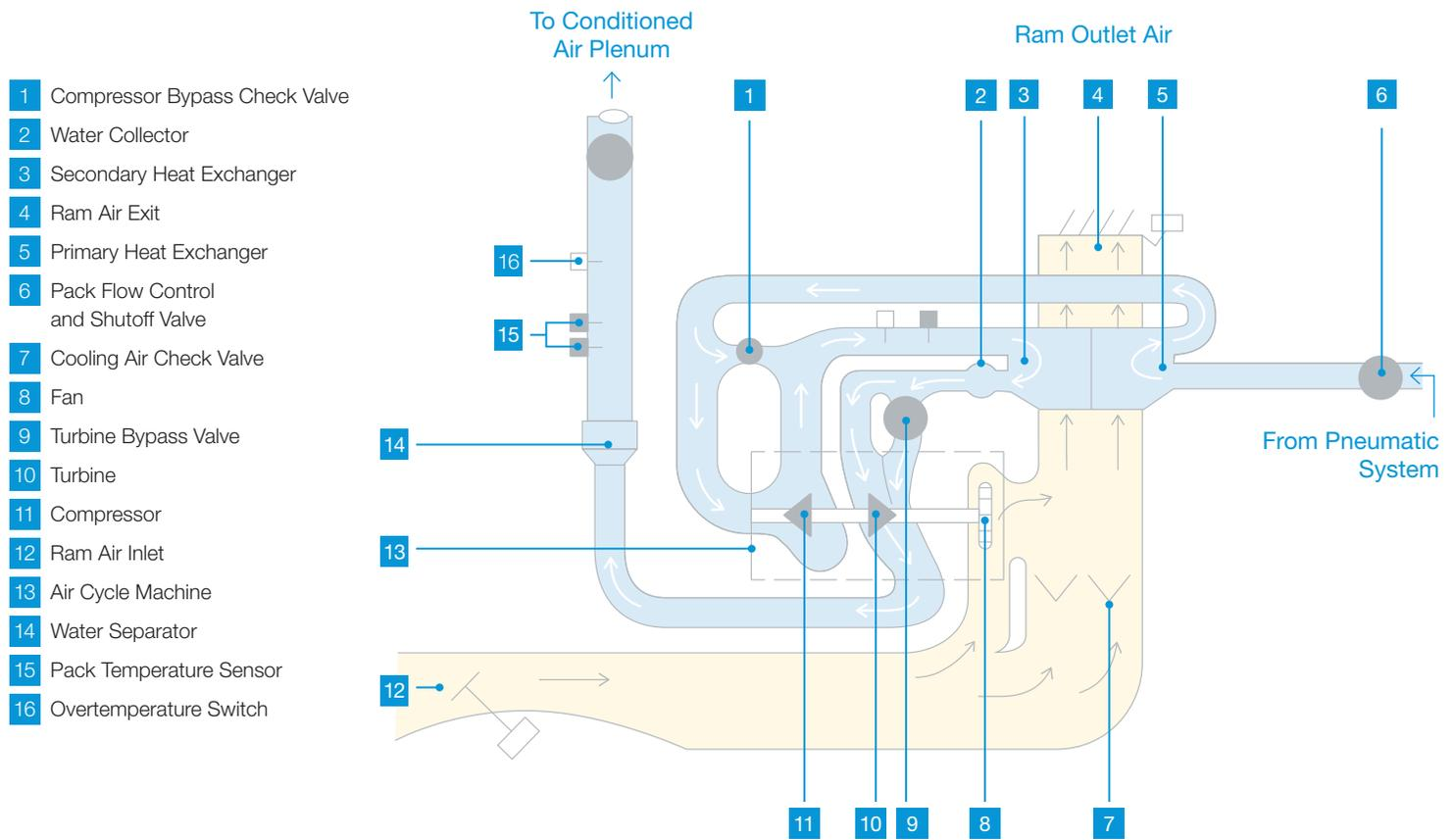

- 1 Compressor Bypass Check Valve
- 2 Water Collector
- 3 Secondary Heat Exchanger
- 4 Ram Air Exit
- 5 Primary Heat Exchanger
- 6 Pack Flow Control and Shutoff Valve
- 7 Cooling Air Check Valve
- 8 Fan
- 9 Turbine Bypass Valve
- 10 Turbine
- 11 Compressor
- 12 Ram Air Inlet
- 13 Air Cycle Machine
- 14 Water Separator
- 15 Pack Temperature Sensor
- 16 Overtemperature Switch

cooled below its dew point as it travels through the condenser section. Within the condenser section, water droplets are formed, allowing water to be removed from the system.

The water extractor then removes the water particles from the high pressure in the ACM by creating a vortex, which forces the water to collect at the walls of the unit. The dried air then passes into the reheater, where the air is again raised to the temperature of the air entering the water extraction loop before entering the ACM turbine inlet.

The water that is removed is then injected into the ram heat exchanger cooling air inlet by means of the water

injectors to increase cooling efficiency of the ram air subsystem. This functionality is particularly critical for ground operations.

**Integrated pack control.** The pack temperature is modulated using the ram air door actuators (RADAs) and the temperature control valve (TCV). The RADAs modulate the ram air flow to regulate ACM compressor outlet temperature.

The TCV position controls the amount of hot air that bypasses the turbine, allowing it to adjust the ACM speed and subsequent pack discharge temperature downstream of the water extractor prior to flow injection into the ACM turbine section.

The ability to adjust this temperature in conjunction with the necessary components and controls to sense flow restrictions associated with ice buildup within the ACM enables the system to avoid and control ice formation within the condenser. In addition, the ability to control the temperature within this stage of the ACM operation increases the efficiency and performance of the high-pressure water extraction process.

The components and technology provided within the ACM allow the unit to function as a cooling unit with increased capacity due to the use of a “defrost cycle,” as required to mitigate the presence of ice. This protects the pack against the damage

**Figure 2B: 747-8 air-conditioning pack**

A diagram of the 747-8 air-conditioning pack system.

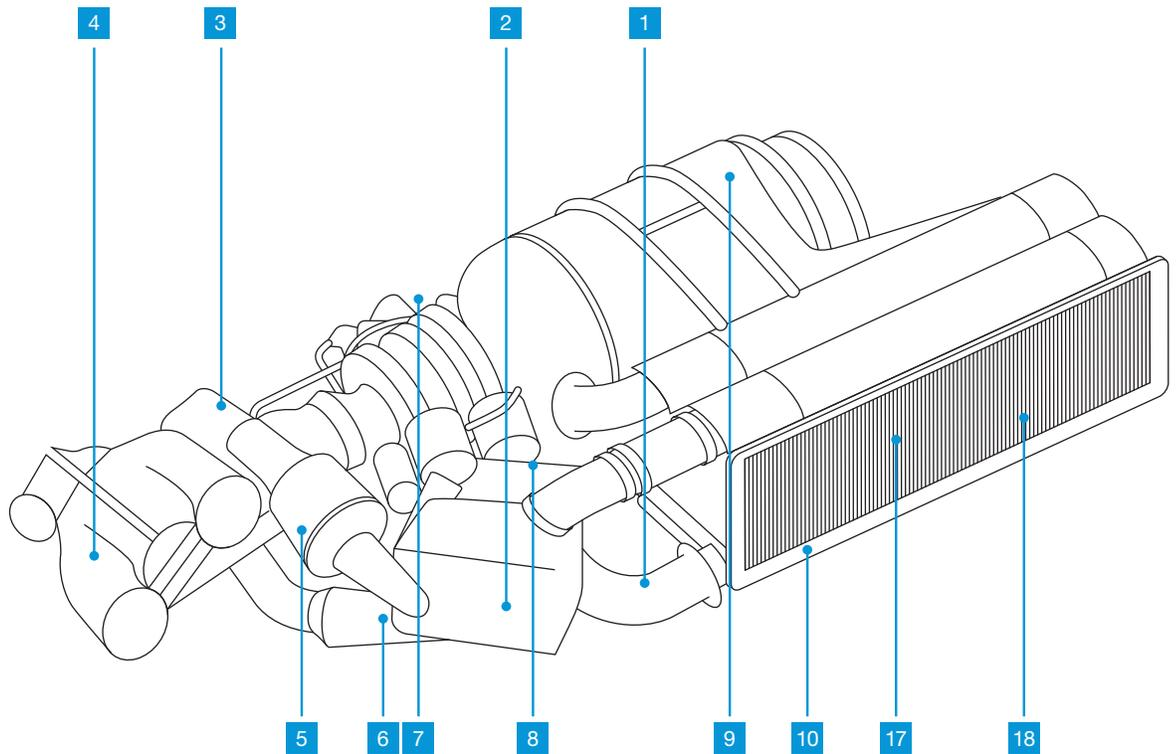
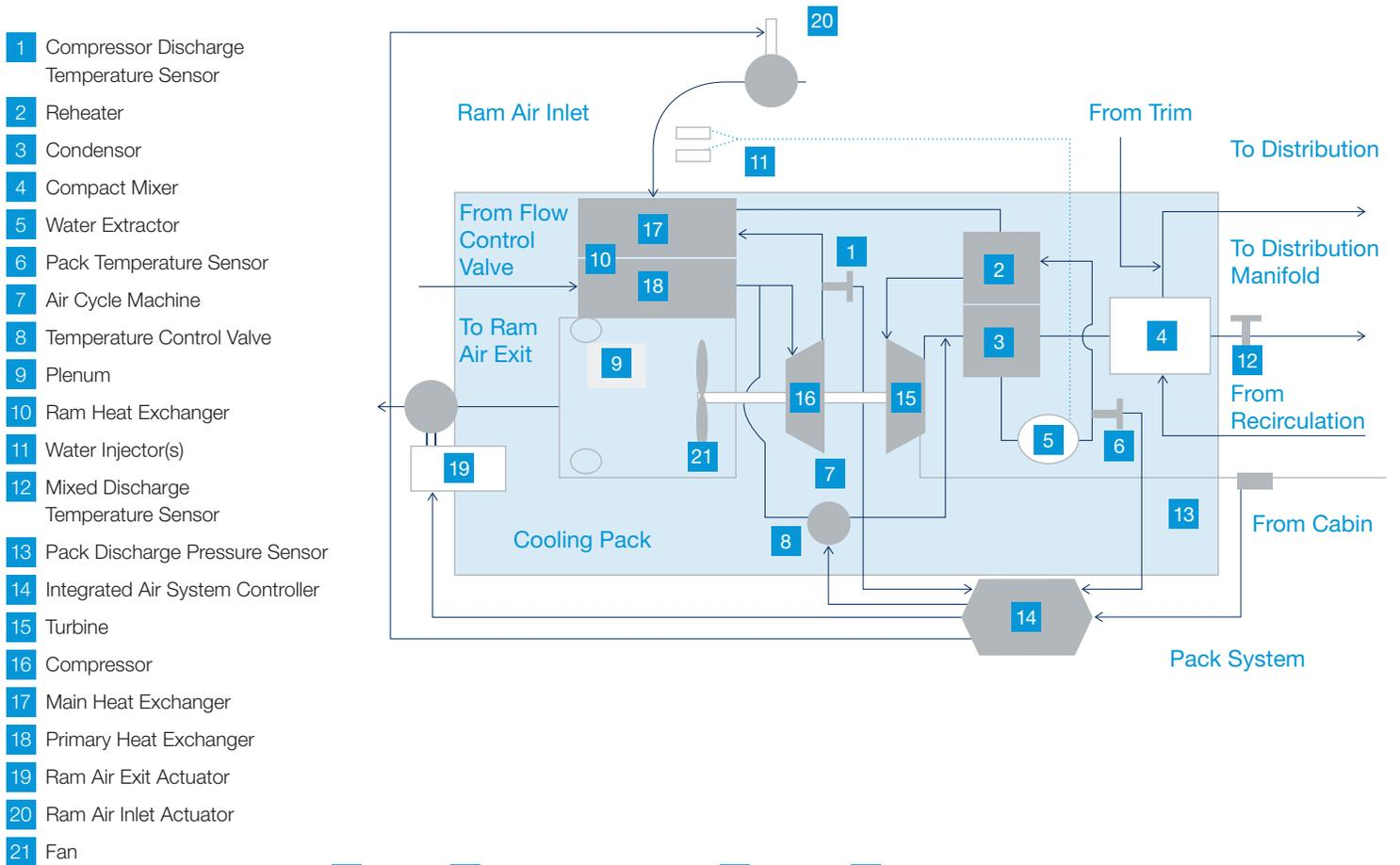

**Figure 3: 747-400 and 747-8 interface similarity**

Flight deck controls for the new environmental control system are very similar to those on the 747-400, easing the transition to the new airplane for flight crews.

**Cabin air-conditioning and temperature control system panel:  
747-400 Freighter**

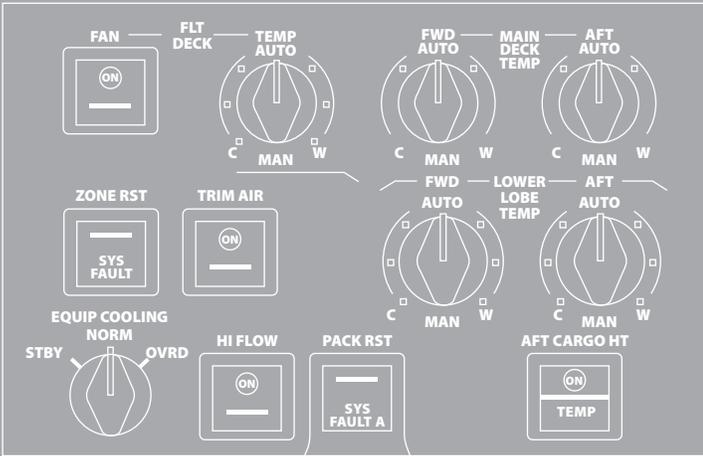

**747-8 Freighter**

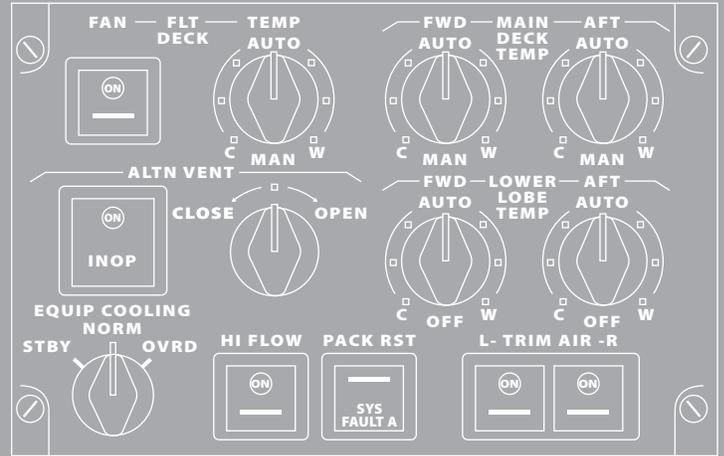

**Air supply control system panel:  
747-400**

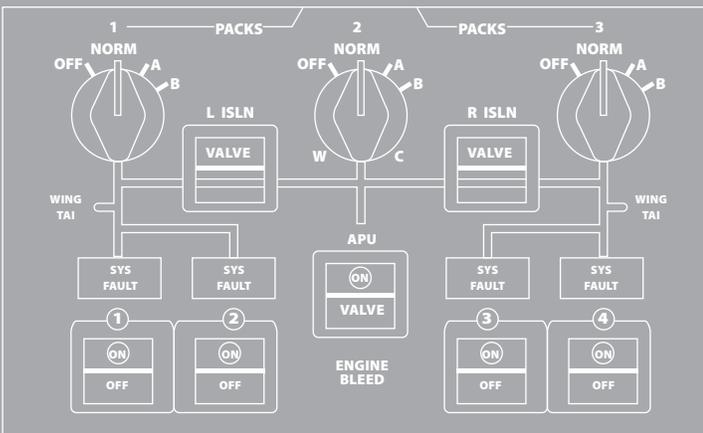

**747-8**

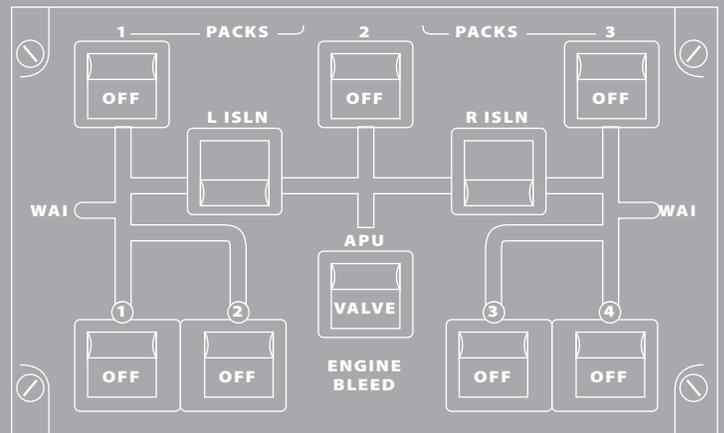

**Cabin air-conditioning and temperature control system panel:  
747-400 Passenger**

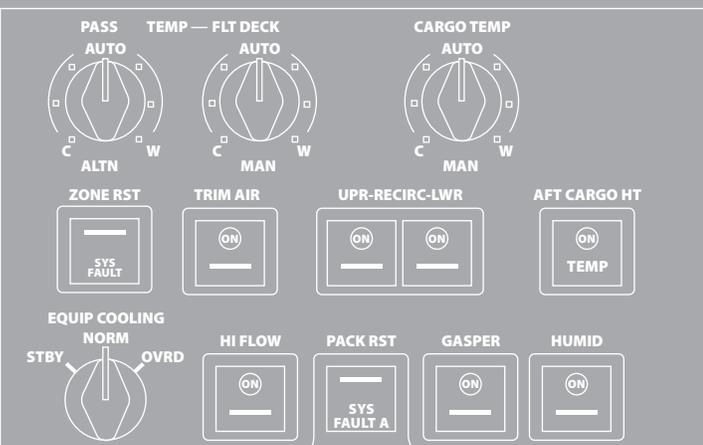

**747-8 Passenger**

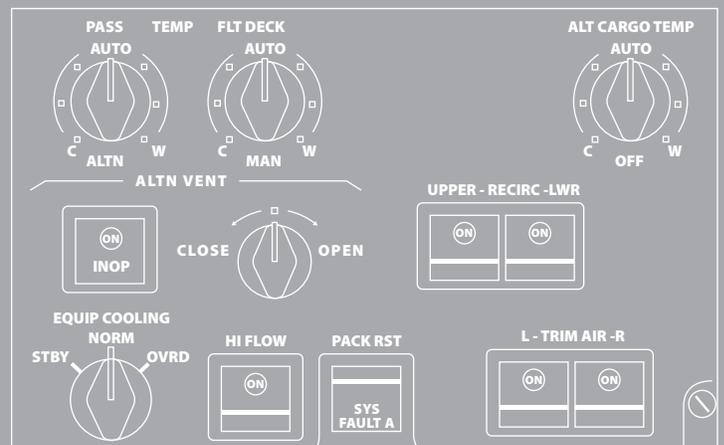

that could be caused by ice buildup within the ACM. Because of this capability, the 747-8 pack can safely operate below freezing and provide increased cooling capacity during all operating conditions.

**Compact mixing section.** The pack discharge air from the ACM turbine section is then sent to the compact mixer prior to distribution into the main airplane cabin area. The compact mixer ensures the efficient mixing of outside air delivered by the ACM with recirculated air from the main cabin zones. Consequently, rather than controlling the pack discharge temperature downstream of the turbine directly, the compact mixer outlet temperature is controlled according to the following schedule, which is strictly based on altitude:

- From 0 to 25,000 feet (0 to 7,620 meters), control the minimum outlet temperature to 37 degrees F (3 degrees C).
- From 25,000 to 30,000 feet (7,620 to 9,144 meters), control the minimum outlet temperature linearly from 37 degrees F (3 degrees C) at 25,000 feet (7,620 meters) to 29 degrees F (-2 degrees C) at 30,000 feet (9,144 meters).
- Above 30,000 feet (9,144 meters), control the minimum outlet temperature to 29 degrees F (-2 degrees C).

In this way, the compact mixer allows the turbine discharge temperature to float well below freezing to directly address the air-conditioning load imposed by the recirculated air from the main cabin zones and allows the pack to provide more of its available capacity as a result. For example, during hot-day ground conditions with very warm recirculated air injection, the pack has the capacity to drive cold, as necessary, to maintain a temperature above 37 degrees F (3 degrees C) at the discharge downstream of the compact mixer section.

#### FAMILIAR FLIGHT DECK INTERFACES

The monitoring and control functions of ASCS and CACTCS are integrated in centralized software that is fit into three interchangeable digital controllers. System control has been managed to keep a flight deck interface similar to the 747-400 (see fig. 3).

#### NEW APPROACH TO IN-SERVICE REQUESTS

The new 747-8 ECS also represents a new way of managing in-service requests designed to provide operators with the fastest possible response. In-service

requests will be coordinated closely with Liebherr-Aerospace, the supplier of key components in the system. The Liebherr-Aerospace Customer Support & Services network deployed for the 747-8 includes spares, repair, and field support services stationed in China, France, Germany, Russia, Singapore, United Arab Emirates, and the United States. A Liebherr-Aerospace field service representative will work closely with customers.

Liebherr will also be available to help respond to in-service requests. Customers can send support service requests to Boeing or contact Liebherr's field service engineering staff directly.

#### SUMMARY

The new ECS on the 747-8 takes advantage of new technology to offer greater capacity, increased efficiency, and improved maintainability while maintaining a flight deck interface similar to that on the 747-400. In-service requests will be coordinated closely with Liebherr-Aerospace, the supplier of key components in the system.

For more information, please contact André Basseur at [andre.g.basseur@boeing.com](mailto:andre.g.basseur@boeing.com). 



A new approach to developing and publishing updates to SRMs shows the potential to provide operators with approved repairs more quickly.

# Making Structural Repairs Faster and More Cost Effective

Boeing has developed a new process that has shown dramatic reductions in the time required for Boeing to develop and publish updates to structural repair manuals (SRMs) for the 737-300/-400/-500 and the 747-400. Based on promising results from these initial two airplane models used in the pilot program, Boeing is expanding the use of the approach to other models.

By **Partha Mukhopadhyay**, Technical Integration Manager, Customer Support Engineering

The large fleet of Boeing airplanes in service experiences structural damage for multiple reasons, such as hail and storm debris striking the airplane, normal wear and tear, and damage incurred by contact with ground equipment. Thousands of custom repair requests are engineered by Boeing every year, and the cost of such custom work is high for both operators and Boeing.

One way to reduce custom work is to add new standard repairs to SRMs as quickly as possible so that they are easily accessible to all operators. However, traditionally SRM revisions take a long time to develop and publish because of the large number of steps involved in the process.

In a recent pilot program, a new process developed by Boeing has demonstrated the potential to dramatically reduce flow times. Reductions of up to 90 percent were seen in pilot study samples. By reducing this process flow time, operators were able to receive approved standard structural repair data much sooner.

This article describes the new SRM process and how it will benefit operators.

## INCREASED DEMAND FOR STRUCTURAL REPAIR DATA

During a recent 15-year period, Boeing has seen a significant increase in demand for approved structural repair data requests

from operators and now receives thousands of requests for repairs annually (see fig. 1).

In response to this demand, Boeing is taking a proactive step to provide repair solutions ahead of time. Operators have the opportunity to participate in the process so that in the future they can use standard repairs rather than requesting custom repairs from Boeing.

When an operator identifies structural damage to an airplane that is not covered by a standard published repair in the SRM, they send a request to Boeing for a repair method. The request goes to an engineer who specializes in the area of the airplane that is damaged, who then develops a repair that meets U.S. Federal

## Figure 1: Requests for approved structural repair data

The number of requests for approved repair data has increased nearly sixfold since 1992.

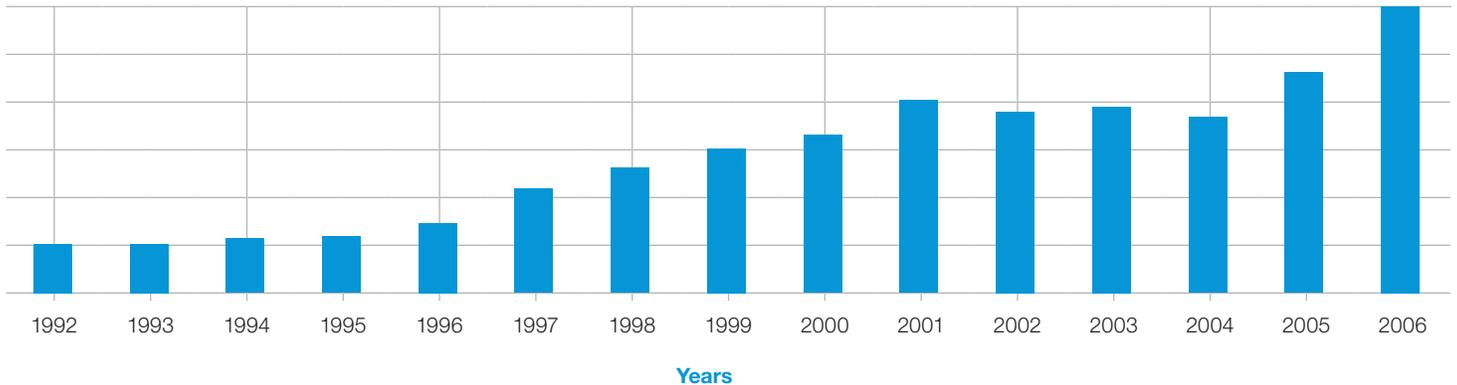

Aviation Administration (FAA) regulations. The operator accomplishes this custom repair and submits documentation of the repair as accomplished. These documents are examined and, if found compliant with FAA regulations, an FAA authorized representative (AR) approves the repair and the operator receives a signed FAA Form 8100-9. Each repair is designed for a specific airplane and cannot be used for another airplane.

If the same repair condition is found on multiple airplanes, Boeing develops a common repair that can be used successfully on any airplane of that type. The repair is then approved by the FAA AR and added to that airplane model's SRM, eliminating the need for an operator to contact Boeing for repair information. By using a standard repair in the SRM, the operator saves on engineering research time and the time needed to communicate with Boeing to request a custom repair, thereby completing repairs in a shorter time.

Due to the complexity of developing these types of approved repairs and the number of steps involved in the process, adding a new repair to the SRM could take more than a year. Realizing operators could benefit from getting this information faster, Boeing committed to improving the SRM revision process.

The result is a new collaborative process in which Boeing SRM engineers and stress engineers are physically co-located in a

work cell and work together on developing repairs, eliminating transfer and queuing steps in the process. Each work cell is assigned an AR and a specific structural repair project. The work cell remains dedicated to the project until final approval. By utilizing Lean principles, the new process significantly reduces the time required for a new repair to be added to an SRM.

The SRM pilot program was based on a limited set of projects on two airplane models, the 737-300/-400/-500 and the 747-400. The success of the SRM pilot program has led Boeing to implement it on additional airplane models. The time savings that will be achieved when the program is fully rolled out and implemented on additional models are yet to be determined.

### BENEFITS TO OPERATORS

Operators will realize several specific benefits with the new process including:

- Increased coverage of repairs in the SRM.
- The time taken to coordinate between operator, manufacturer, and regulatory agency is reduced.
- Airplane downtime reduction.
- Cost reduction.

### WHAT OPERATORS CAN DO

Selecting the appropriate repair areas for development and incorporation into the

SRMs is a team effort between operators and Boeing. Operators can improve the process by sharing information about areas of concern with Boeing so that Boeing can address the areas of need with published repairs. Boeing recommends that operators provide input about structural damage and locations requiring SRM coverage in IdeaXchange on the Web portal MyBoeingFleet.com.

In addition, by being aware of the increased supply of published standard repairs in the SRM, operators are encouraged to check the SRM for solutions during heavy maintenance prior to contacting Boeing.

### SUMMARY

A new streamlined approach to developing and publishing updates to SRMs shows the potential to provide operators with approved repairs more quickly. This can save operators time by providing them with the repair they need without making additional requests to Boeing. Boeing will be expanding the new process from the two airplane models used in the pilot to additional in-production models.

For more information, please contact Customer Support Engineering at [customersupportengineeringaero@boeing.com](mailto:customersupportengineeringaero@boeing.com). 



